

DOOR DETAIL

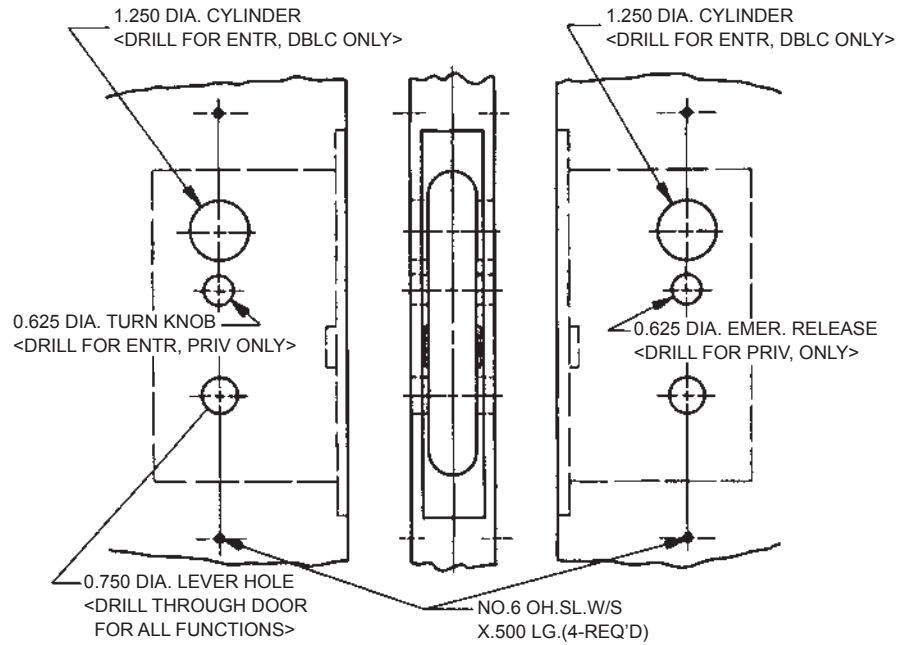

TRIM DETAIL

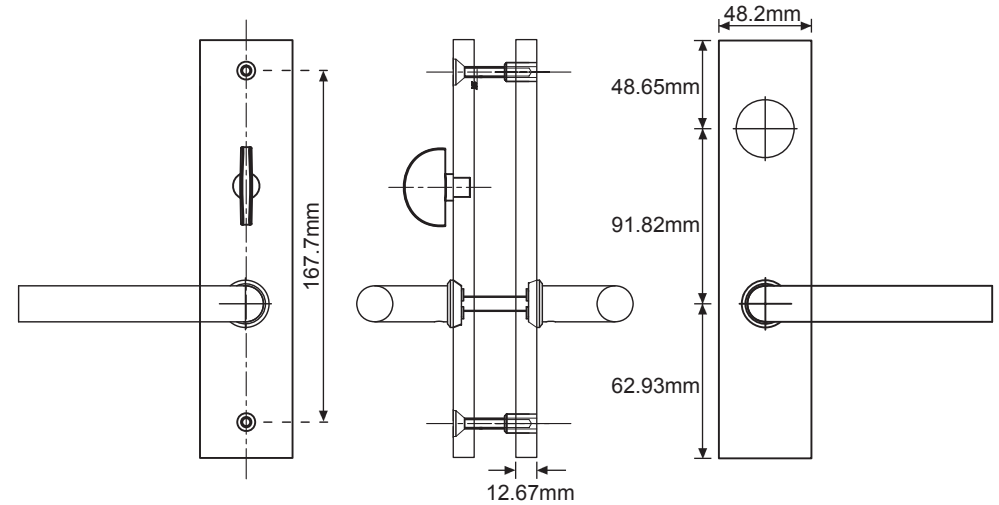

INSIDE

OUTSIDE

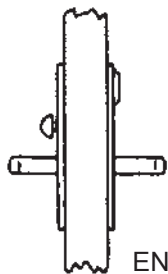

ENTRANCE

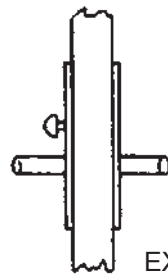

EXTR

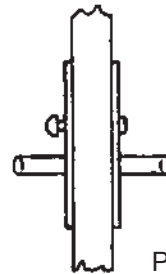

PRIV

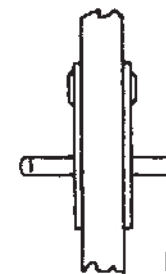

DOUBLE CLY.

NOTE:
FOR ADDITIONAL LOCK AND DOOR CUTOUT DIMENSIONS,
SEE APPROPRIATE LOCK TEMPLATE.
LTM8003 / MTM8002 / LTM8001

			Selina	12.05.11
標記	處數	文件編號	簽字	日期
設計			審核	
製圖			工藝	
描圖			標準	
校對			審定	

TCE TRIM	數量	零件圖號		
		裝配圖號		
	材	料	共	張
	SUS304		重	量
		比	例	
Lutér® 崧日企業有限公司				